

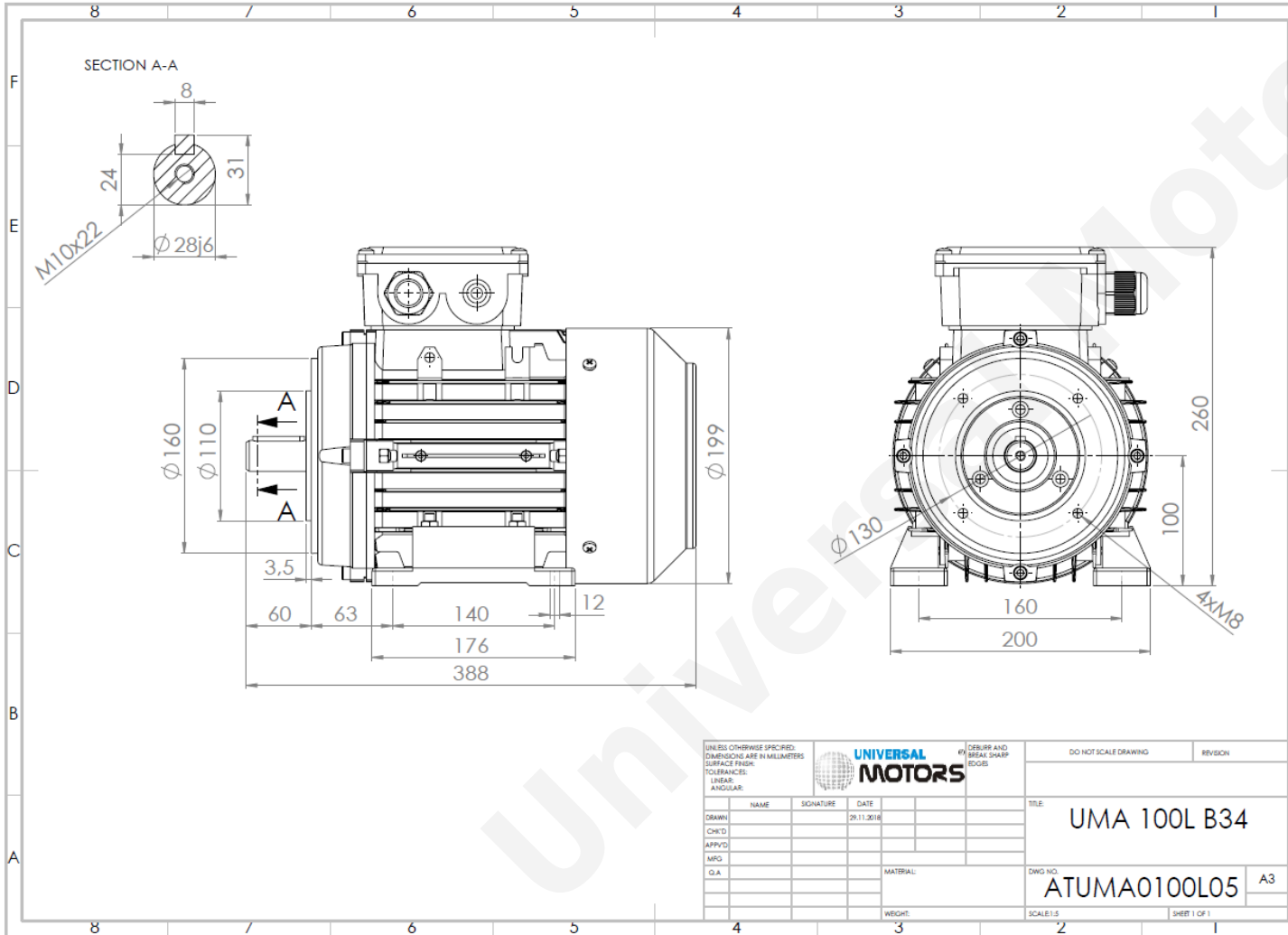

TECHNICAL DATA

Three Phase Electric Motors - Aluminum Frame
 UM3A 132M2-2 IE3
 11 kW / 15 Cv
 RPM



Motor type:	UM3A 132M2-2 IE3
Output:	11 kW / 15 Cv
Frequency:	50 Hz
Voltage:	400 V
Current:	18.9 A
Power factor (Cos Ø):	0.92
Poles:	2
Insulation class:	F
Temperature rise Class:	B
Efficiency 50%:	91.2 %
Efficiency 75%:	91.5 %
Efficiency 100%:	91.2 %
Torque:	35.8 N.m
Tstarting/Tnominal:	3.6
Istarting/Inominal:	12.2
Tmaximum/Tnominal:	4.1
Noise:	83 Db(A)
Weight:	63.5 Kg
Brake AC:	AC7A
Torque Brake DC:	80 N.m
Bearing DE:	6308 2Z
Bearing NDE:	6308 2Z
Torque Brake AC:	90 N.m
Brake DC:	REB-05-16

Regime - S1

Altitude - 1000m

Environment Temperature - 40°C

CONTACTS:

UNIVERSAL MOTORS Tel: +351 252 299 080
 Rua de São Brás,745 Fax: +351 252 299 089
 4480-782 VILA DO CONDE Mail: geral@universalmotors.pt

* References applied only in the UK